

MODEL	CHRYSLER MODEL NO.	KVA @ 50% DUTY CYCLE	PRIMARY VOLT/FREQ	SECONDARY VOLTAGE (DC)	TURNS RATIO	WEIGHT
				LO-TAP HI-TAP	LO-TAP HI-TAP	LBS
TDC-1070	91-901-1201	170	650/1000	9.5 13.0	68:1 50:1	100
TDC-5628		170	800/1000	9.5 13.1	84:1 61:1	100

COOLING REQUIREMENTS: 2 GPM PER CIRCUIT @ 30°C MAX  
4 GPM TOTAL

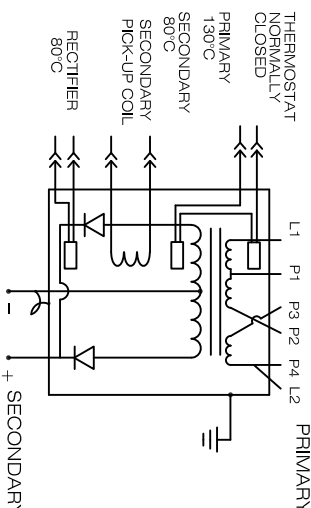
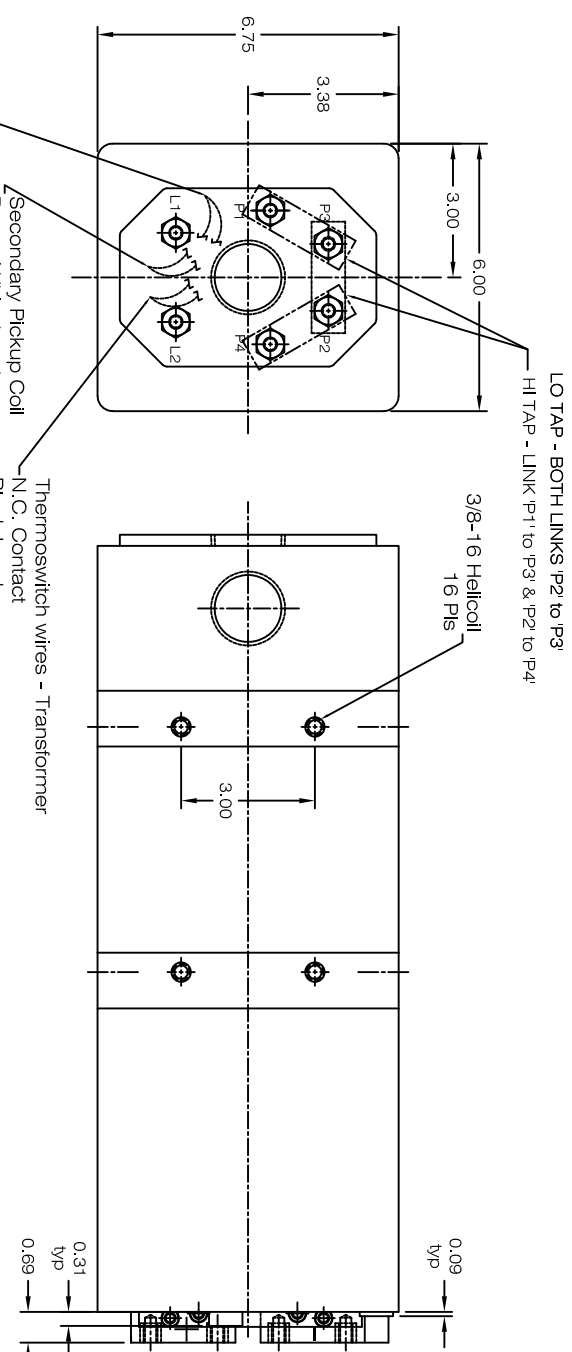
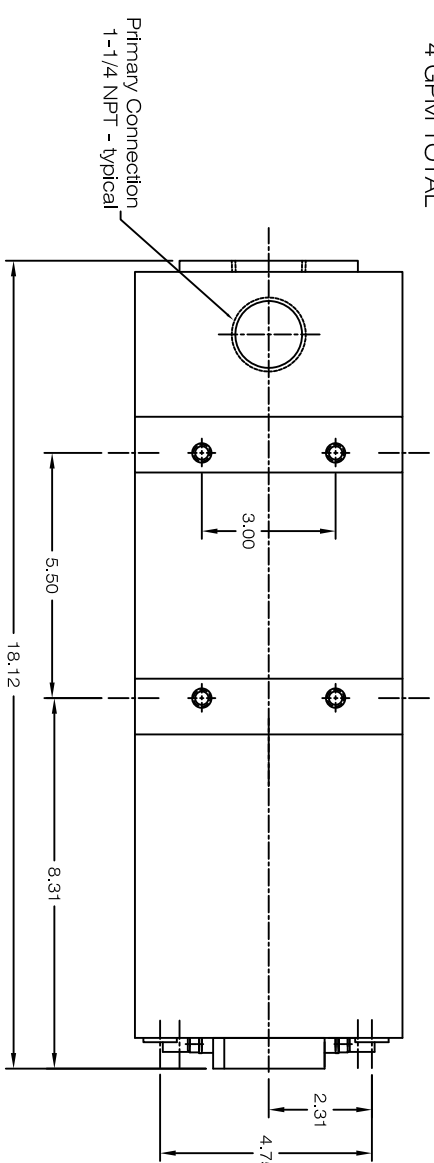

TRANSFORMER CASE MUST BE GROUNDED.  
TRANSFORMER WILL BE SHIPPED WITH A JUMPER  
CONNECTING SECONDARY CENTER TAP TO CASE.  
USER MUST PROVIDE APPROPRIATE GROUNDING  
OF SECONDARY CIRCUIT. FOR APPLICATIONS  
ABOVE A 20% DUTY CYCLE, CONTACT ROMAN  
MANUFACTURING FOR ASSISTANCE.

NOTE\*  
The secondary terminals of this device  
are intended as an electrical connection only.  
Applications must be designed to minimize  
any forces applied to the secondary terminals,  
this can be accomplished by transferring forces  
to a structural member.

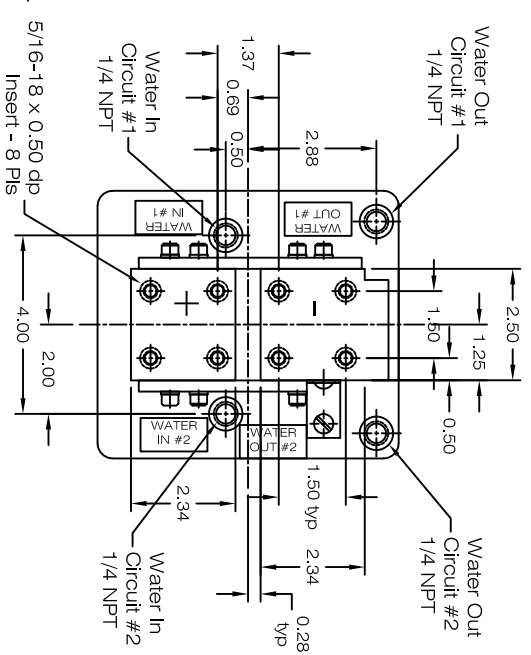

REV	DESCRIPTION	DATE
U	ADDED WATER LABELS PER MFG. REQUEST	08JAN15
T	RADIUS COVER TO ADD RADIUS BACK ON RECT. COVER	29SEP09
S	ADDED REMOVABLE GROUND STRAP TO WIRE SCHEMATIC	20OCT09

DATE: 10/15/09  
DRAWN BY: KRM  
CHECKED BY: AGG  
DATE: 10/15/09

TDC-1070 POWER SUPPLY

1010330

# Power Supply Rating Diagram, Single Phase, Center Tap Rectifier. "Size 4" Rectifier

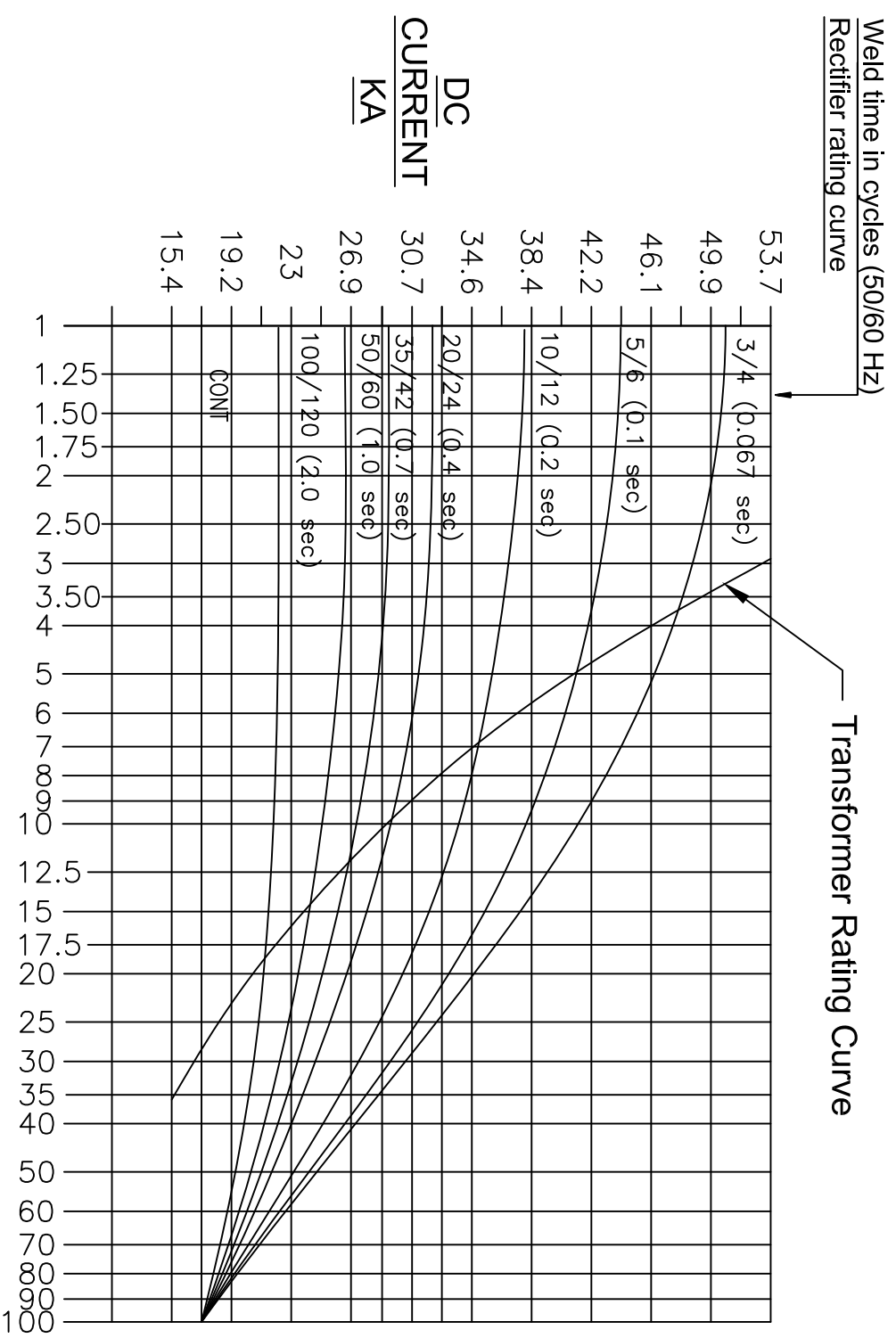

**DUTY CYCLE (%)**

Where used  
 TDC-1026  
 TDC-1058  
 TDC-1062  
 TDC-1070  
 TDC-1078  
 TDC-1116  
 TDC-1131  
 TDC-5517  
 TDC-5620  
 TDC-6599  
 TDC-8143

**Notes:**  
 These curves are based on rated water flow of 4 G.P.M (15 L.P.M.).  
 Maximum water in temperature of 30°C.  
 For applications above a 20% duty cycle, contact Roman Manufacturing for assistance.  
**Rectifier Rating:**  
 % Duty Cycle is based on shortest time from beginning of one weld to the beginning of next weld. On time/(On + Off time).  
**Transformer Rating:**  
 % Duty Cycle is total "On" time in one minute.

REV	DESCRIPTION	DATE
04Apr18	Added TDC--8143 to Where Used List	KLY
04Jun07	Added line for 35/42 cycles/0.7s	KLY
THIS DRAWING AND ALL THE INFORMATION AND TECHNOLOGY IN IT ARE EXCLUSIVE, CONFIDENTIAL AND PROPRIETARY TO ROMAN MFG., INC. THIS DRAWING IS OWNED BY ROMAN MFG., INC. AND UNLESS SPECIFICALLY AUTHORIZED IN WRITING, NO COPIES SHALL BE MADE OF THIS DRAWING, AND SHALL BE USED ONLY FOR THE LIMITED PURPOSE FOR WHICH IT IS DISCLOSED AND ONLY TO THE BENEFIT OF ROMAN MFG., INC. AND IT AND ANY COPIES, AUTHORIZED OR NOT, SHALL BE IMMEDIATELY RETURNED UPON ANY REQUEST THEREFOR.		
SCALE:	NONE	DRAWN BY: KLY
DATE:	1JUL98	WEIGHT:
Rating Curve		
		DRAWING NUMBER: 1110079