

TUFFALOY MISCELLANEOUS TIPS

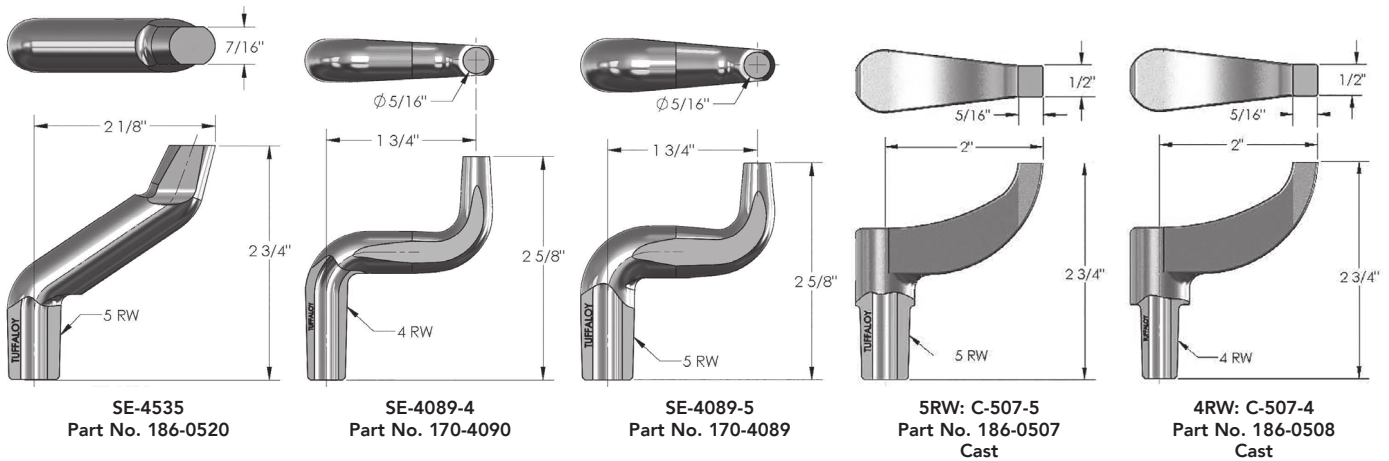

These straight tips have welding faces angled 30°.

Alloy Class	Taper No.	Face 'C'	Length 'D'	Description	Part No.
2	4RW	1/4	2	H-2408-30	145-2408
2	4RW	1/4	3	H-2412-30	145-2412
2	4RW	1/4	4	H-2416-30	145-2416
2	5RW	3/8	2	H-2508-30	145-2508
2	5RW	3/8	3	H-2512-30	145-2512
2	5RW	3/8	4	H-2516-30	145-2516

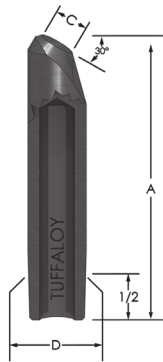

Alloy Class	Taper No.	Length 'N'	Description	Part No.
2	4RW	3/8	N-15	186-0015
2	4RW	3/4	N-16	186-0016
2	5RW	3/8	N-27	186-0027
2	5RW	3/4	N-28	186-0028

N-15 thru N-28

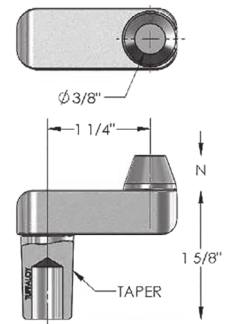

BACK UP ELECTRODES

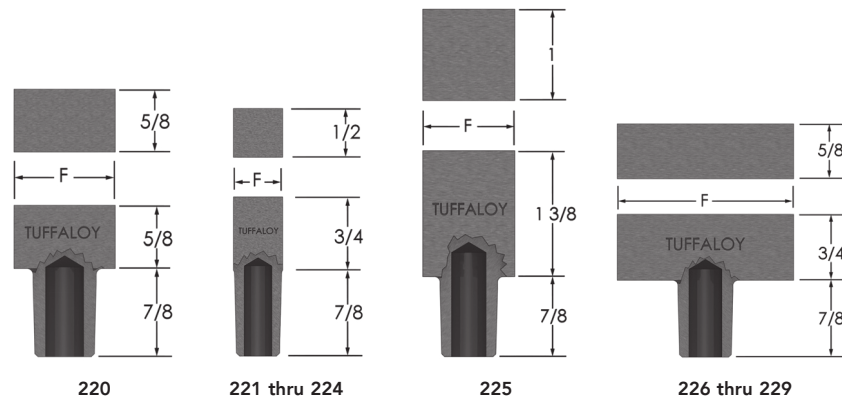

These tips are all machined from bar stock. Special designs can be made to order.

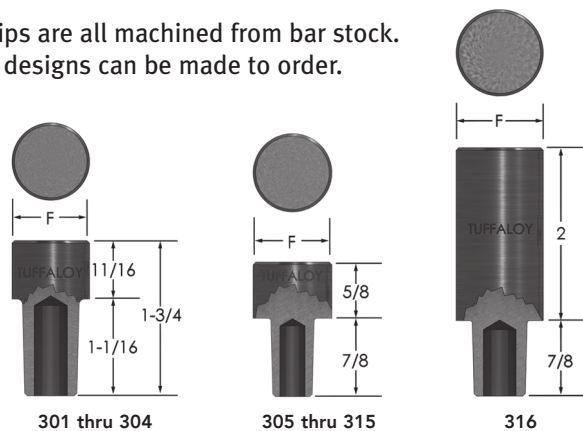

*311, 313 and 316 available with Copper Tungsten face.

RECTANGULAR FACE

Alloy Class	Taper No.	Face 'F'	Description	Part No.
2	5RW	1	220	186-0220
2	4RW	1/2	221	186-0221
2	4RW	1	223	186-0223
2	5RW	1	224	186-0224
2	5RW	1	225	186-0225
2	5RW	2	226	186-0226
2	4RW	2	227	186-0227
2	5RW	1-1/2	228	186-0228
2	4RW	1-1/2	229	186-0229

ROUND FACE

Alloy Class	Taper No.	Face 'F'	Description	Part No.
2	4RW	7/8	301	186-0301
1	4RW	7/8	302	186-0302
2	5RW	7/8	303	186-0303
1	5RW	7/8	304	186-0304
2	4RW	7/8	305	186-0305
1	4RW	7/8	306	186-0306
2	5RW	7/8	307	186-0307
1	5RW	7/8	308	186-0308
2	4RW	1	309	186-0309
1	4RW	1	310	186-0310
2	5RW	1	311*	186-0311
1	5RW	1	312	186-0312
2	5RW	1-1/4	313*	186-0313
2	5RW	1-1/2	315	186-0315
2	5RW	1	316*	186-0316

Additional Back Up Electrodes with Copper Tungsten Facings – See Page 36

