

Swivel tips have ball-jointed swivel heads to compensate for minor misalignment, and to eliminate marking of the work surface. They are all machined from Class 2 (C18200) bar stock. The S- and SS-Series tip water hole does not reach the head. In the OS and OSH models, the water does contact the head, and O-rings are used to seal it. In the SS Series a spring is used to keep pressure on head for better positioning. **Class 1 (C15000) and Class 3 (C18000) heads are also available.**

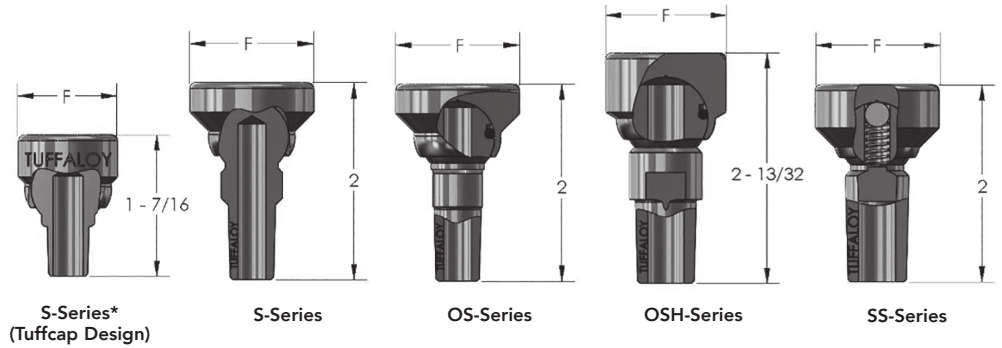

Taper No.	Face Dia. 'F'	S-Series		OS-Series		OSH-Series		SS-Series	
		Description	Part No.	Description	Part No.	Description	Part No.	Description	Part No.
5-CT*	7/8	S-248	182-0248						
	1	S-249	182-0249						
	1-1/4	S-250	182-0250						
4RW	7/8	S-348	182-0348	OS-348	182-1348				
	1	S-350	182-0350	OS-350	182-1350				
	1-1/4	S-351	182-0351	OS-351	182-1351				
5RW	7/8	S-349	182-0349	OS-349	182-1349	OSH-353	182-2353	SS-353	182-3353
	1	S-353	182-0353	OS-353	182-1353	OSH-354	182-2354	SS-354	182-3354
	1-1/4	S-354	182-0354	OS-354	182-1354	OSH-356	182-2356		
	2					OSH-358	182-2358		
7RW	2-1/2					3360	182-3360		

Note: Standard swivel tilt is approximately 18°, a 25° swivel is available on request. Add suffix “-HS” to above part number.

*Will fit Tuffcap adapter shanks having No. 5 RW tapers, as shown on [page 8](#).

TUFFALOY REFRACTORY METAL-FACED TIPS

Nose Type	Taper No.	Facing Alloy Class	Dimensions		Description	Part No.
			A	B		
Pointed	4RW	14	3/16	3/8	A-2408-100M	185-0120
	4RW	13	3/16	3/8	A-2408-100W	185-0130
	5RW	11	1/4	3/8	A-2508-10W	185-0150
	5RW	14	1/4	3/8	A-2508-100M	185-0160
	5RW	13	1/4	3/8	A-2508-100W	185-0170
Dome	4RW	11	1/2	1/4	B-2408-10W	185-1110
	5RW	11	5/8	1/4	B-2508-10W	185-1120
	5RW	13	5/8	1/4	B-2508-100W	185-1170
Flat	4RW	11	1/2	1/4	C-2408-10W	185-1210
	4RW	14	1/2	1/4	C-2408-100M	185-1220
	4RW	13	1/2	1/4	C-2408-100W	185-1230
	5RW	11	5/8	1/4	C-2508-10W	185-1250
	5RW	14	5/8	1/4	C-2508-100M	185-1260
	5RW	13	5/8	1/4	C-2508-100W	185-1270

The **TUFFALOY** copper-tungsten, tungsten and molybdenum-faced tips listed here withstand greater heat and pressure, at the expense of some conductivity. Besides being used for spot welding high resistance base metals, they are useful in achieving “heat balance” when welding dissimilar metals. (The higher resistance electrode is used against the lower resistance, or thinner, member, to help contain the heat generated.) They have the same diameters and tapers as the standard straight tips in this catalog. Bodies are of Class 2 (C18200) alloy. Lengths other than those shown can be ordered.

