

TUFFALOY threaded electrode adapters are used to provide longer electrode holder life, by providing a changable tip socket in holders having threaded openings. Class 2 (C18200) alloy. Other alloys available.

A Pipe Thread or Taper	B Taper Socket	C Body Size	D Body Length	E Over-All Length	Description	Part Number
1/2-14 NPT	4RW	1" Hex	1/4	7/8	AD-124-.8	190-1408
			3/8	1	AD-124-1.0	190-1410
			5/8	1-1/4	AD-124-1.2	190-1412
			7/8	1-1/2	AD-124-1.5	190-1415
			1-1/8	1-3/4	AD-124-1.7	190-1417
			1-3/8	2	AD-124-2.0	190-1420
			1-5/8	2-1/4	AD-124-2.2	190-1425
			1-7/8	2-1/2	AD-124-2.5	190-1425
			2-1/8	2-3/4	AD-124-2.7	190-1430
			2-3/8	3	AD-124-3.0	190-1430
			2-5/8	3-1/4	AD-124-3.2	190-1435
			2-7/8	3-1/2	AD-124-3.5	190-1435
			3-1/8	3-3/4	AD-124-3.7	190-1440
			3-3/8	4	AD-124-4.0	190-1440
			4-3/8	5	AD-124-5.0	190-1440
			1/2-14 NPT	5RW	1" Hex	1/4
3/8	1	AD-125-1.0				190-1510
5/8	1-1/4	AD-125-1.2				190-1512
7/8	1-1/2	AD-125-1.5				190-1515
1	1-5/8	AD-125-1.6				190-1517
1-1/8	1-3/4	AD-125-1.7				190-1517
1-3/8	2	AD-125-2.0				190-1520
1-5/8	2-1/4	AD-125-2.2				190-1525
1-7/8	2-1/2	AD-125-2.5				190-1525
2-1/8	2-3/4	AD-125-2.7				190-1530
2-3/8	3	AD-125-3.0				190-1530
2-5/8	3-1/4	AD-125-3.2				190-1532
2-7/8	3-1/2	AD-125-3.5				190-1535
3-1/8	3-3/4	AD-125-3.7				190-1537
3-3/8	4	AD-125-4.0				190-1540
3-7/8	4-1/2	AD-125-4.5				190-1545
5/8-14 NPT	4RW	1" Hex	1/4	7/8	AD-584-.8	190-2408
			3/8	1	AD-584-1.0	190-2410
			7/8	1-1/2	AD-584-1.5	190-2415
			1-3/8	2	AD-584-2.0	190-2420
5/8-14 NPT	5RW	1" Hex	1/4	7/8	AD-585-.8	190-2508
			3/8	1	AD-585-1.0	190-2510
			5/8	1-1/4	AD-585-1.2	190-2512
			7/8	1-1/2	AD-585-1.5	190-2515
			1-1/8	1-3/4	AD-585-1.7	190-2517
			1-3/8	2	AD-585-2.0	190-2520
			1-7/8	2-1/2	AD-585-2.5	190-2525
			2-3/8	3	AD-585-3.0	190-2530
3-3/8	4	AD-585-4.0	190-2540			
3/4-14 NPT	5RW	1.25 Hex	3/16	1-1/8	AD-345-1.1	190-3511
			7/16	1-3/8	AD-345-1.3	190-3513
			9/16	1-1/2	AD-345-1.5	190-3515
			13/16	1-3/4	AD-345-1.7	190-3517
			1-1/16	2	AD-345-2.0	190-3520
			1-9/16	2-1/2	AD-345-2.5	190-3525
			2-1/16	3	AD-345-3.0	190-3530
			2-9/16	3-1/2	AD-345-3.5	190-3535
			3-1/16	4	AD-345-4.0	190-3540
			4-1/16	5	AD-345-5.0	190-3550
3/4-14 NPT	6RW	1.25 Hex	5/16	1-1/4	AD-346-1.2	190-3613
			7/16	1-3/8	AD-346-1.3	190-3613
			9/16	1-1/2	AD-346-1.5	190-3615
			1-1/16	2	AD-346-2.0	190-3620
			1-9/16	2-1/2	AD-346-2.5	190-3625
			1-13/16	2-3/4	AD-346-2.7	190-3627
			2-1/16	3	AD-346-3.0	190-3630
			2-9/16	3-1/2	AD-346-3.5	190-3635
			3-1/16	4	AD-346-4.0	190-3640
			3-9/16	4-1/2	AD-346-4.5	190-3645
3/4-14 NPT	7RW	1.25 Hex	9/16	1-1/2	AD-347-1.5	190-3715
			1-1/16	2	AD-347-2.0	190-3720
			1-9/16	2-1/2	AD-347-2.5	190-3725
			2-1/16	3	AD-347-3.0	190-3730
			2-9/16	3-1/2	AD-347-3.5	190-3735
			3-1/16	4	AD-347-4.0	190-3740
			3-9/16	4-1/2	AD-347-4.5	190-3745
			4-1/16	5	AD-347-5.0	190-3750
4RW	5RW	1" Hex	1	2	AD-45-2	190-4520
			2	3	AD-45-3	190-4530
			3	4	AD-45-4	190-4540
5RW	4RW	7/8 Hex	1/4	1-1/8	AD-54-1	190-5410
			1	2	AD-54-2	190-5420
			1-1/2	2-1/2	AD-54-2.5	190-5425
			2	3	AD-54-3	190-5430
			3	4	AD-54-4	190-5440
5RW	5RW	7/8 Hex	1	2	AD-55-2	190-5520
			1-1/2	2-1/2	AD-55-2.5	190-5525
			2	3	AD-55-3	190-5530
			3	4	AD-55-4	190-5540
5RW	5RW	7/8 Hex	4	5	AD-55-5	190-5550
5RW 6RW 6RW 7RW	6RW 4RW 5RW 4RW	1" Hex 1" Hex 1" Hex 1" Hex	1-1/8	2	AD-56-2	190-5620
			1/4	1-1/4	AD-64-1	190-6410
			1/4	1-1/4	AD-65-1	190-6510
			1/4	1-1/2	AD-74-1	190-7410
7RW	5RW	1" Hex	1/4	1	AD-75-1	190-7510
			3/4	2	AD-75-2	190-7520
			2-1/4	3-1/2	AD-75-3.5	190-7535
			2-3/4	4	AD-75-4	190-7540

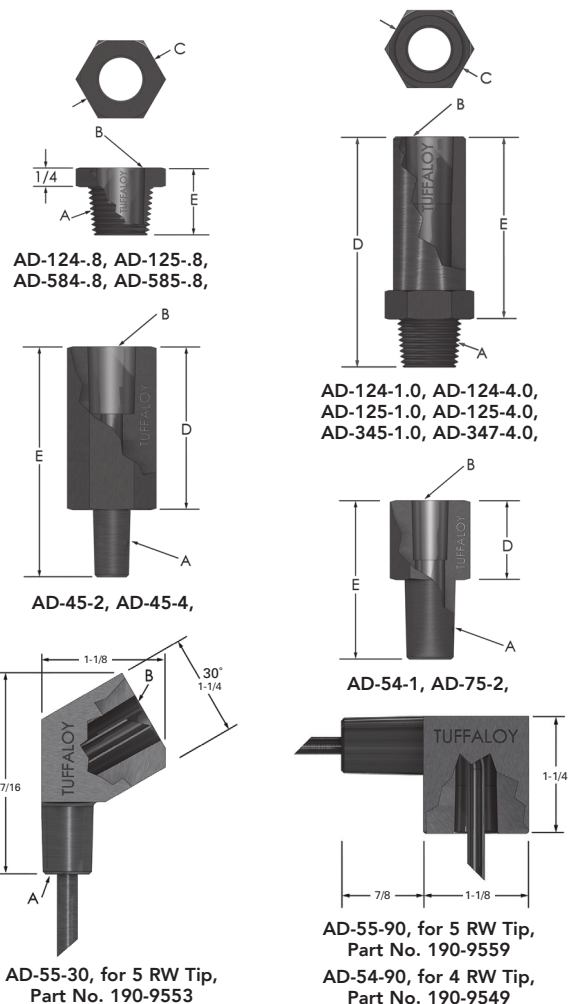

**STRAIGHT THREADED ADAPTERS FOR MULTI-SPOT BARREL AND CLAMP**

A	B	C	Description	Part No.
<b>D = 4 RW TAPER - E = 7/8-14 NF</b>				
3/8	1-1/8	1.25 Hex	AD-134-1.1	190-3211
1/2	1-1/4		AD-134-1.2	190-3212
5/8	1-3/8		AD-134-1.3	190-3213
3/4	1-1/2		AD-134-1.5	190-3215
1	1-3/4		AD-134-1.7	190-3217
1-1/4	2		AD-134-2.0	190-3220
1-1/2	2-1/4		AD-134-2.2	190-3222
1-3/4	2-1/2		AD-134-2.5	190-3225
2-1/4	3		AD-134-3.0	190-3230
2-3/4	3-1/2		AD-134-3.5	190-3235
<b>D = 5 RW TAPER - E = 7/8-14 NF</b>				
3/8	1-1/8	1.25 Hex	AD-135-1.1	190-3311
1/2	1-1/4		AD-135-1.2	190-3312
5/8	1-3/8		AD-135-1.3	190-3313
3/4	1-1/2		AD-135-1.5	190-3315
1	1-3/4		AD-135-1.7	190-3317
1-1/4	2		AD-135-2.0	190-3320
1-1/2	2-1/4		AD-135-2.2	190-3322
1-3/4	2-1/2		AD-135-2.5	190-3325
2-1/4	3		AD-135-3.0	190-3330
2-3/4	3-1/2		AD-135-3.5	190-3335
<b>D = 5 RW TAPER - E = 1-12 NF</b>				
3/8	1-1/8	1.25 Hex	AD-105-1.1	190-4311
1/2	1-1/4		AD-105-1.2	190-4312
5/8	1-3/8		AD-105-1.3	190-4313
3/4	1-1/2		AD-105-1.5	190-4315
1	1-3/4		AD-105-1.7	190-4317
1-1/4	2		AD-105-2.0	190-4320
1-1/2	2-1/4		AD-105-2.2	190-4322
1-3/4	2-1/2		AD-105-2.5	190-4325
2	2-3/4		AD-105-2.7	190-4327
2-1/4	3		AD-105-3.0	190-4330
2-3/4	3-1/2	AD-105-3.5	190-4335	

