

TUFFALOY PLATEN-MOUNTED HOLDERS

PM HOLDERS

TUFFALOY PM holders may be mounted directly to press-type welder platens, or they can be used as components of special weld fixturing. They come in two sizes, which match standard T-slot spacings (either of which can be furnished to hold any of the four standard tips: 4, 5, 6 or 7 RW). The smaller holder is for use on RWMA Size 1 welders, which have the 3-1/2" spacing. The larger one is for the Size 2 and 3 welders, which have the 5- and 6-inch spacing.

Big, half-inch mounting bolts may be used to assure good conductivity. The holders may be used one-to-one or in multiples closely bunched. PM holders make special fixture building easy. They can be bolted to a fixture or back-up base as easily as to a platen. They are compact and have self-contained coolant systems. These PM holders are made of Class 2 (C18200) alloy.

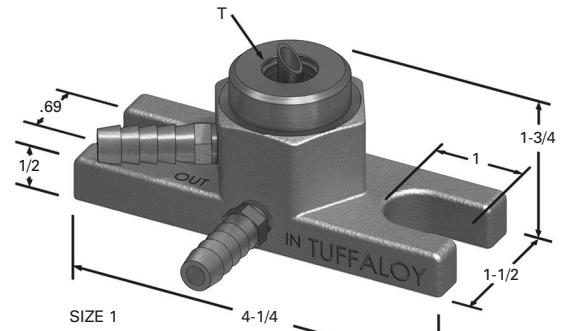

Size 1 PM Holder (5/8" mounting bolts)

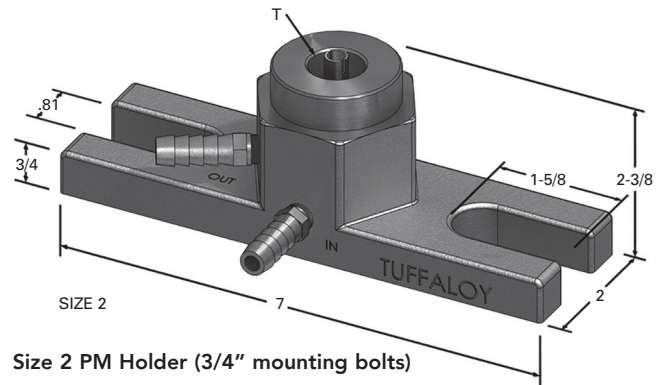

Size 2 PM Holder (3/4" mounting bolts)

STANDARD TIP PM HOLDERS				
RW Tip Socket	Size 1 (Small)		Size 2 (Large)	
	Description	Part No.	Description	Part No.
4	4560	350-4560	4570	350-4570
5	4561	350-4561	4571	350-4571
6	4562	350-4562	4572	350-4572
7	4563	350-4563	4573	350-4573

FOR THREADED ELECTRODES		
Thread Size	Size 1	Size 2
5/8-11	350-4580	350-4590
3/4-10	350-4581	350-4591

FOR THREADED ADAPTERS		
Thread Size	Size 1	Size 2
7/8-14	350-4582	350-4592
1-12	350-4583	350-4593

See adapters [page 17](#)

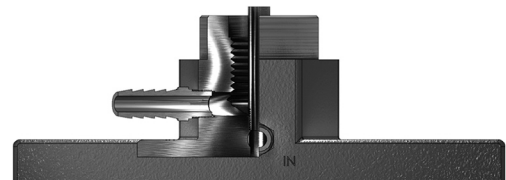
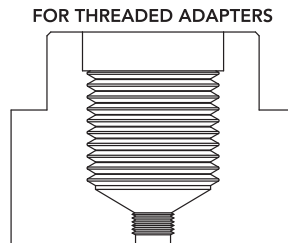
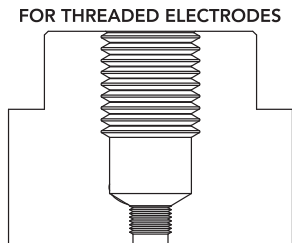

NUT AND STUD PM HOLDERS					
PM Holders T-Slot Spacing	Holder Size	For 1" Dia. Electrodes		For 1-1/2" Dia. Electrodes	
		Description	Part No.	Description	Part No.
3-1/2	1PM	4515	350-4515	4526	350-4526
5 & 6	2PM	4525	350-4525		

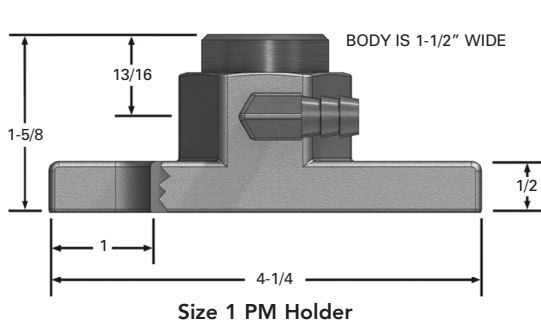

Size 1 PM Holder

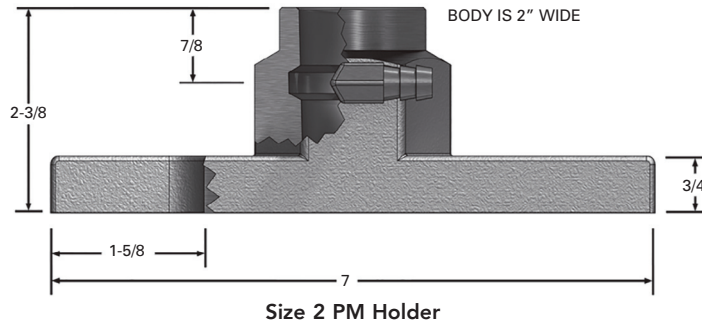

Size 2 PM Holder

