

TUFFALOY NUT AND STUD WELDING

ELECTRODE HOLDERS

U.S. Pat. No. 3,504,159 Canada Pat. No. 858,060

Tuffaloy Straight and Offset electrode holders are manufactured to accommodate all the nut and stud electrode tips.

STRAIGHT NUT AND STUD WELDING HOLDERS

Shank OD	A Dia.	B Length	For 1" Dia. Electrodes		For 1-1/2" Dia. Electrodes	
			Description	Part No.	Description	Part No.
1	1-3/4	5-5/8	4530	350-4530		
1-1/4	1-3/4	5-5/8	4531	350-4531		
1-1/2	1-3/4	5-5/8	4532	350-4532		
1	2	5-3/4			4535	350-4535
1-1/4	2	5-3/4			4536	350-4536
1-1/2	2	5-3/4			4537	350-4537

OFFSET NUT AND STUD WELDING HOLDERS

Shank OD	For 1" Dia. Electrodes		For 1-1/2" Dia. Electrodes	
	Description	Part No.	Description	Part No.
1	4540	350-4540		
1-1/4	4541	350-4541	4546	350-4546
1-1/2	4542	350-4542	4547	350-4547

Straight and Offset Holders - Tuffaloy straight and offset nut and stud electrode holders are of the same high quality as the standard straight holders made for spot welder arm mounting. Coolant is brought to the tip and circulated around it. Holders are available in three barrel diameters.

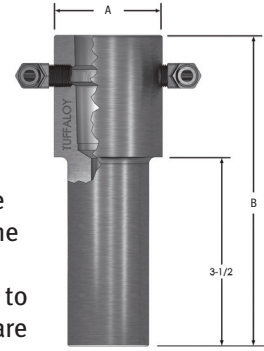

Straight Holder

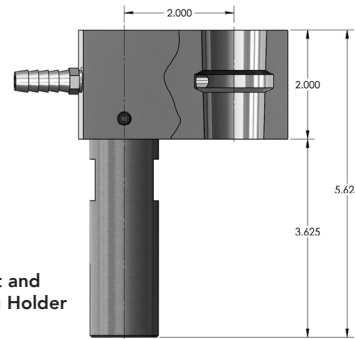

Offset Nut and Stud Welding Holder

ARCTIC HOLDERS

ARCTIC STUD ELECTRODES

A For Stud Diameter	B Electrode Length	C Electrode Diameter	Description	Part Number	Shank Size
#06 (.150)	3	1-1/4	115	175-1151-X	
#08 (.164)			116	175-1161-X	
#10 (.190)			119	175-1191-X	
#12 (.216)			122	175-1221-X	
1/4			125	175-1252-X	
5/16 & 8mm			131	175-1312-X	
3/8			138	175-1382-X	
7/16			144	175-1442-X	
6mm			106	175-1061-X	
7mm			107	175-1071-X	
9mm			109	175-1092-X	
10mm			110	175-1102-X	
1/2			3	1-1/2	150
9/16	156	175-1563-X			
5/8	163	175-1633-X			
11/16	169	175-1693-X			
12mm	112	175-1123-X			

ARCTIC NON-PILOTED-NUT ELECTRODES

H For Nut Diameter	J Pilot Diameter	K Electrode Length	L Electrode Diameter	Description	Part Number	Shank Size		
#08 (.164)	0.180	4	1-1/4	216	175-2162-X			
#10 (.190)	0.215			219	175-2192-X			
#12 (.216)	0.240			222	175-2222-X			
1/4	0.275			225	175-2252-X			
5/16 & 8mm	0.345			231	175-2312-X			
3/8	0.405			238	175-2382-X			
6mm	0.251			206	175-2062-X			
7mm	0.300			207	175-2072-X			
9mm	0.385			209	175-2092-X			
10mm	0.425			210	175-2102-X			
7/16	0.562			4	1-1/2	244	175-2443-X	
1/2	0.625					250	175-2503-X	
9/16	0.687	256	175-2563-X					
12mm	0.595	212	175-2123-X					

Arctic Electrodes - The Arctic system is a compact stud-and-nut electrode with internal water cooling. Also available with optional air expulsion and platen mounts.

Patent Pending

