

**ULTRAPRESSURE™ FAST FOLLOW-UP HOLDER SYSTEM**

*U.S. Patent Pending*

TUFFALOY'S UltraPressure™ Fast Follow-Up Holder System is a low profile, spring loaded electrode holder designed specifically for new or existing resistance welding tooling that requires the additional follow-up force. Available in a range of forces from 750 to 10,000 lbs., utilizing easily replaceable dies springs to configure the holder to the weld application. These holders are especially effective for projection welding on AHSS, and in conjunction with Fast Rise Time (FRT) Transformers. UltraPressure body weighs 8.8 lbs.

ULTRAPRESSURE FAST FOLLOW-UP HOLDER SYSTEM				
ULTRAPRESSURE BODY			MOUNTING OPTIONS	
Part No.	Force at Compression (Lbs.)		Part No.	Description
	0.063"	0.125"		
350-4640	375	750	195-5680	5 RW Mount
350-4641	700	1250	195-7063	Cylinder Mount**
350-4642	1000	2000	195-7060	1.00" OD Shank Mount
350-4643	1500	2750	195-7061	1.25" OD Shank Mount
350-4644	1850	3500	195-7062	1.50" OD Shank Mount
350-4650	3250	6500	195-6146	Platen Mount
350-4652	5000	10000		**Fits Clamp 194-2040

*To specify the electrode mounting type, please add one of these suffix's to the holder body part number (-5RW, -6RW, -7RW, -.875 for 7/8-14 or -1.0 for 1-12).*

**ULTRAPRESSURE BODY**  
-SEE CHART FOR MOUNTING OPTIONS-

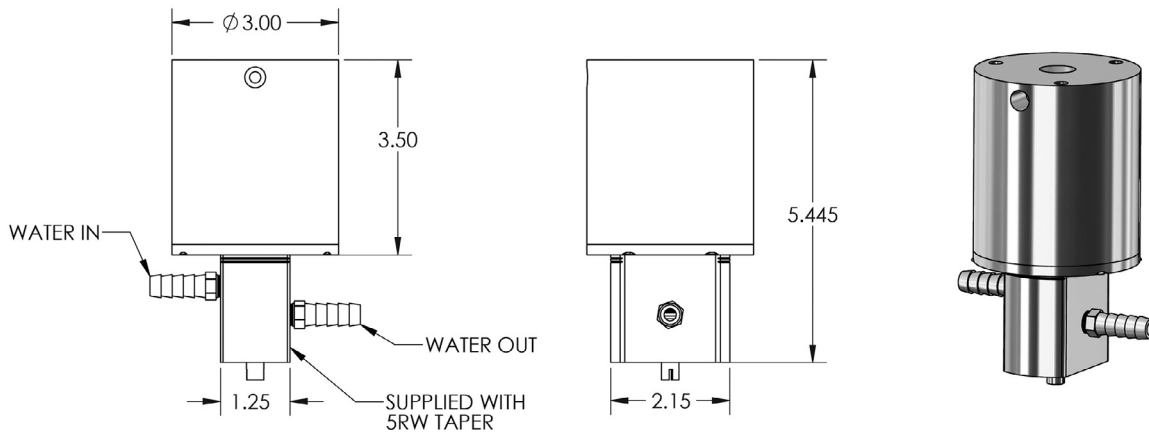

**MOUNTING OPTIONS**

