

TUFFALO STANDARD STRAIGHT TIPS

KEY TO DESCRIPTION

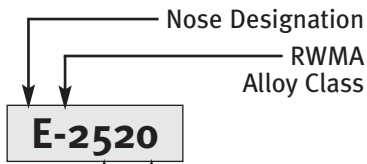

Nose Designation
RWMA Alloy Class
E-2520
RW Taper No.
Length, in Number of 1/4-in. increments
Example: E nose, class 2, 5RW taper, 5" length
Contact us if Class 3 (17510) alloy is required

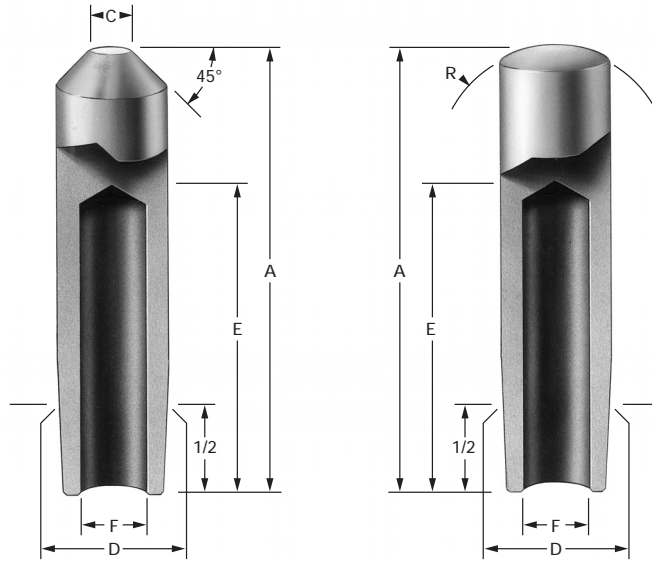

'E' TRUNCATED CONE

C Welding Face Dia.	RWMA CLASS 1		RWMA CLASS 2	
	Descrip- tion	Part No.	Descrip- tion	Part No.
3/16	E-1404	140-1404	E-2404	140-2404
3/16	E-1405	140-1405	E-2405	140-2405
3/16	E-1406	140-1406	E-2406	140-2406
3/16	E-1407	140-1407	E-2407	140-2407
3/16	E-1408	140-1408	E-2408	140-2408
3/16	E-1409	140-1409	E-2409	140-2409
3/16	E-1410	140-1410	E-2410	140-2410
3/16	E-1411	140-1411	E-2411	140-2411
3/16	E-1412	140-1412	E-2412	140-2412
3/16	E-1413	140-1413	E-2413	140-2413
3/16	E-1414	140-1414	E-2414	140-2414
3/16	E-1415	140-1415	E-2415	140-2415
3/16	E-1416	140-1416	E-2416	140-2416

'F' RADIUS FACED

R Nose Radius	RWMA CLASS 1		RWMA CLASS 2	
	Descrip- tion	Part No.	Descrip- tion	Part No.
2	F-1404	141-1404	F-2404	141-2404
2	F-1405	141-1405	F-2405	141-2405
2	F-1406	141-1406	F-2406	141-2406
2	F-1407	141-1407	F-2407	141-2407
2	F-1408	141-1408	F-2408	141-2408
2	F-1409	141-1409	F-2409	141-2409
2	F-1410	141-1410	F-2410	141-2410
2	F-1411	141-1411	F-2411	141-2411
2	F-1412	141-1412	F-2412	141-2412
2	F-1413	141-1413	F-2413	141-2413
2	F-1414	141-1414	F-2414	141-2414
2	F-1415	141-1415	F-2415	141-2415
2	F-1416	141-1416	F-2416	141-2416

NO. 4 RW TAPER - 1/2" DIAMETER

A Overall Length	D Gauging Dia.	E Water Hole Depth	F Water Hole Dia.
1	.463	1/2	9/32
1-1/4	.463	3/4	9/32
1-1/2	.463	1	9/32
1-3/4	.463	1-1/4	9/32
2	.463	1-1/2	9/32
2-1/4	.463	1-3/4	9/32
2-1/2	.463	2	9/32
2-3/4	.463	2-1/4	9/32
3	.463	2-1/2	9/32
3-1/4	.463	2-3/4	9/32
3-1/2	.463	3	9/32
3-3/4	.463	3-1/4	9/32
4	.463	3-1/2	9/32

NO. 5 RW TAPER - 5/8" DIAMETER

A Overall Length	D Gauging Dia.	E Water Hole Depth	F Water Hole Dia.
1-1/4	.613	3/4	3/8
1-1/2	.613	3/4	3/8
1-3/4	.613	1	3/8
2	.613	1-1/4	3/8
2-1/4	.613	1-1/2	3/8
2-1/2	.613	1-3/4	3/8
2-3/4	.613	2	3/8
3	.613	2-1/4	3/8
3-1/4	.613	2-1/2	3/8
3-1/2	.613	2-3/4	3/8
3-3/4	.613	3	3/8
4	.613	3-1/4	3/8

NO. 6 RW TAPER - 3/4" DIAMETER

A Overall Length	D Gauging Dia.	E Water Hole Depth	F Water Hole Dia.
2	.731	1-1/4	7/16
2-1/2	.731	1-3/4	7/16
3	.731	2-1/4	7/16
3-1/2	.731	2-3/4	7/16
4	.731	3-1/4	7/16

NO. 7 RW TAPER - 7/8" DIAMETER

A Overall Length	D Gauging Dia.	E Water Hole Depth	F Water Hole Dia.
2	.844	1-1/4	1/2
2-1/2	.844	1-3/4	1/2
3	.844	2-1/4	1/2
3-1/2	.844	2-3/4	1/2
4	.844	3-1/2	1/2

C Welding Face Dia.	Descrip- tion	Part No.	Descrip- tion	Part No.
1/4	E-1505	140-1505	E-2505	140-2505
1/4	E-1506	140-1506	E-2506	140-2506
1/4	E-1507	140-1507	E-2507	140-2507
1/4	E-1508	140-1508	E-2508	140-2508
1/4	E-1509	140-1509	E-2509	140-2509
1/4	E-1510	140-1510	E-2510	140-2510
1/4	E-1511	140-1511	E-2511	140-2511
1/4	E-1512	140-1512	E-2512	140-2512
1/4	E-1513	140-1513	E-2513	140-2513
1/4	E-1514	140-1514	E-2514	140-2514
1/4	E-1515	140-1515	E-2515	140-2515
1/4	E-1516	140-1516	E-2516	140-2516

R Nose Radius	Descrip- tion	Part No.	Descrip- tion	Part No.
2	F-1505	141-1505	F-2505	141-2505
2	F-1506	141-1506	F-2506	141-2506
2	F-1507	141-1507	F-2507	141-2507
2	F-1508	141-1508	F-2508	141-2508
2	F-1509	141-1509	F-2509	141-2509
2	F-1510	141-1510	F-2510	141-2510
2	F-1511	141-1511	F-2511	141-2511
2	F-1512	141-1512	F-2512	141-2512
2	F-1513	141-1513	F-2513	141-2513
2	F-1514	141-1514	F-2514	141-2514
2	F-1515	141-1515	F-2515	141-2515
2	F-1516	141-1516	F-2516	141-2516

C Welding Face Dia.	Descrip- tion	Part No.	Descrip- tion	Part No.
9/32	E-1608	140-1608	E-2608	140-2608
9/32	E-1610	140-1610	E-2610	140-2610
9/32	E-1612	140-1612	E-2612	140-2612
9/32	E-1614	140-1614	E-2614	140-2614
9/32	E-1616	140-1616	E-2616	140-2616

R Nose Radius	Descrip- tion	Part No.	Descrip- tion	Part No.
4	F-1608	141-1608	F-2608	141-2608
4	F-1610	141-1610	F-2610	141-2610
4	F-1612	141-1612	F-2612	141-2612
4	F-1614	141-1614	F-2614	141-2614
4	F-1616	141-1616	F-2616	141-2616

C Welding Face Dia.	Descrip- tion	Part No.	Descrip- tion	Part No.
5/16	E-1708	140-1708	E-2708	140-2708
5/16	E-1710	140-1710	E-2710	140-2710
5/16	E-1712	140-1712	E-2712	140-2712
5/16	E-1714	140-1714	E-2714	140-2714
5/16	E-1716	140-1716	E-2716	140-2716

R Nose Radius	Descrip- tion	Part No.	Descrip- tion	Part No.
6	F-1708	141-1708	F-2708	141-2708
6	F-1710	141-1710	F-2710	141-2710
6	F-1712	141-1712	F-2712	141-2712
6	F-1714	141-1714	F-2714	141-2714
6	F-1716	141-1716	F-2716	141-2716

